

# Compression load cell Inteco<sup>®</sup>, converter Connexx<sup>®</sup>, mounting kits PR 6001, PR 614x

The versatile, innovative weighing solution for silo and vessel weighing



Digital Assistance  
Technology



German Quality

The load cell Inteco<sup>®</sup>/PR 6203 represents a consistent enhancement to the well-known PR 6201. With an output signal of 2 mV/V, additional load levels of up to 75 t, higher accuracy classes (C6) and high-quality stainless steel, it has a wider range of potential applications. As a digital weighing solution with the converter Connexx<sup>®</sup>, the load cell Inteco<sup>®</sup> offers fast signalling times and optimal transparency in dosing and weighing processes. The Minebea Intec mounting kits FLEXLOCK minimise the effect of movements on the weighing result at the same time.

The right solution for all of these applications:



Weighing



Filling and  
dosing



Fill quantity  
control

## Technical specifications

Compression load cell Inteco®/PR 6203 (500 kg – 75 t)						
Parameter	Description	Abbr.	PR 6203 D1/N	PR 6203 C3	PR 6203 C6	Unit
Accuracy class			0.04	0.015	0.008	%E <sub>max</sub>
Minimum dead load	Lowest limit of specified measuring range	E <sub>min</sub>	0			%E <sub>max</sub>
Maximum capacity	Highest limit of specified measuring range	E <sub>max</sub>	See Ordering information table			kg
Safe load limit	Maximum load without irreversible damage	E <sub>lim</sub>	For 500 kg... 50 t: 150 For 60 t: 125 For 75 t: 100			%E <sub>max</sub>
Destructive load	Danger of mechanical destruction	E <sub>d</sub>	For 500 kg... 50 t: >300 For 60 t: >250 For 75 t: >200			%E <sub>max</sub>
Minimum LC verification	Minimum load cell verification interval (v <sub>min</sub> =E <sub>max</sub> /Y)		See Accuracy classes and minimum verification interval, v <sub>min</sub> table			
	For E <sub>max</sub> = 500 kg	Y	2,500	n.a.	n.a.	
	For E <sub>max</sub> = 1 t	Y	5,000	n.a.	n.a.	
	For E <sub>max</sub> = 2 t	Y	5,000	10,000	n.a.	
	For E <sub>max</sub> = 3 t...75 t	Y	5,000	14,000	3 t – 10 t: 14,000 >20 t: 20,000	
Deadload output return	Factor for deadload output return after load (DR=1/2*E <sub>max</sub> /Z)	Z	1,000	3,000	6,000	
Rated output	Relative output at maximum capacity	C <sub>n</sub>	2	2	2	mV/V
Tolerance on rated output	Permissible deviation from rated output	d <sub>c</sub>	<0.25	<0.07	<0.07	%C <sub>n</sub>
Zero output signal	Load cell output signal under unloaded condition	S <sub>min</sub>	0±1.0	0±1.0	0±1.0	%C <sub>n</sub>
Reproducibility	Max. change in load cell output for repeated loading	ε <sub>R</sub>	0.01	0.005	0.005	%C <sub>n</sub>
Creep	Max. change of output signal at E <sub>max</sub> for 30 min.	d <sub>cr</sub>	<0.03	<0.015	<0.008	%C <sub>n</sub>
Non-linearity	Max. deviation from best straight line through zero	d <sub>lin</sub>	<0.03	<0.01	<0.01	%C <sub>n</sub>
Hysteresis	Max. difference in LC output between loading and unloading	d <sub>hy</sub>	<0.04	<0.015	<0.008	%C <sub>n</sub>
Temperature effect (TK) on S <sub>min</sub>	Max. change of S <sub>min</sub> in B <sub>T</sub>	TK <sub>Smin</sub>	<0.028	<0.010	<0.007	%C <sub>n</sub> /10 K
Temperature effect (TK) on parameter	Max. change of C in B <sub>T</sub>	TK <sub>C</sub>	<0.03	<0.010	<0.005	%C <sub>n</sub> /10 K
Input impedance	Between supply terminals	R <sub>LC</sub>	650 ±6	650 ±6	650 ±6	Ω
Output impedance	Between supply terminals	R <sub>O</sub>	610 ±1	610 ±0.5	610 ±0.5	Ω
	For E <sub>max</sub> = 60 t	R <sub>O</sub>	510 ±1	510 ±0.5	510 ±0.5	Ω
	For E <sub>max</sub> = 75 t	R <sub>O</sub>	410 ±1	410 ±0.5	410 ±0.5	Ω
Insulation impedance	Between measuring circuit and housing at 100 V <sub>DC</sub>	R <sub>IS</sub>	>5,000 × 10 <sup>6</sup>			Ω
Insulation voltage	Between circuit and housing (Inteco® only)		500			V
Recommended supply voltage	To hold the specified performance	B <sub>u</sub>	4...24			V
Max. supply voltage	Permissible for continuous operation without damage	U <sub>max</sub>	32 (Ex versions: 25)			V
Nominal ambient temp. range	To hold the specified performance	B <sub>T</sub>	-10...+40	-10...+40	-10...+40	°C
Usable temperature range	Permissible for continuous operation without damage	B <sub>Tu</sub>	-40...+95	-40...+95	-40...+95	°C
Storage temperature range	Without electrical and mechanical stress	B <sub>Tt</sub>	-40...+95	-40...+95	-40...+95	°C
Material (load cell housing)	Stainless steel 1.4301 acc. DIN EN 10088-3 (conforms to 304 AISI)					
Permissible eccentricity	Permissible displacement from nominal load line	S <sub>ex</sub>	For 500 kg... 10 t: 10 For 20 t...75 t: 5			mm
Vibration resistance	Resistance against oscillations (IEC 68-2-6 Fc)		20 g, 100 h, 10... 150 Hz			

Parameter	Description	Abbr.	PR 6203 D1/N	PR 6203 C3	PR 6203 C6	Unit
Barometric pressure influence	Influence of barometric pressure on output	PK <sub>Smin</sub>	500 kg... 3 t: 200 5 t... 10 t: 330 20 t... 75 t: 420			g/kPa
Nominal deflection	Max. elastic deformation under maximum capacity	S <sub>nom</sub>	≤5 t: ≤0.3/≤20 t: ≤0.5/≤50 t: ≤0.8/ 60 t... 75 t: ≤1.2			mm
Protection class	according to IEC 529 – Inteco: IP68*/IP69 – Connexx®: IP65 / IP 68**					
Cable	Length: E <sub>max</sub> ≤10 t: 5 m, E <sub>max</sub> >10 t: 12 m Diameter: 5 mm Cross section: 4 × 0.35 mm <sup>2</sup> Material cable sheath: TPE					
Bending radius	≥25 mm in case of fixed installation ≥75 mm in case of flexible installation					

Connexx®						
Nominal ambient temp. range	To hold the specified performance	B <sub>T</sub>	-10...+40			°C
Usable temperature range	Permissible for continuous operation without damage	B <sub>Tu</sub>	-30...+60			°C
Storage temperature range	Without electrical and mechanical stress	B <sub>Ti</sub>	-30...+70			°C

\* The load cell can be submerged in water at a depth of 1.5 m for 10,000 hours.

\*\* The module can be submerged in water at a depth of 1.5 m for 100 hours.

### Accuracy classes and minimum verification interval, $v_{min}$

	OIML			NTEP Class III Multiple			NTEP Class IIIIL Multiple		
	D1/D1E	C3/C3E	C6/C6E	D1/D1E	C3/C3E	C6/C6E	D1/D1E	C3/C3E	C6/C6E
Maximum number of verification intervals, $n_{max}$	1,000	3,000	6,000	1,000	5,000	10,000	2,000	10,000	10,000
500 kg	0.2 kg	n.a.	n.a.	0.2 kg	n.a.	n.a.	n.a.	n.a.	n.a.
1 t	0.2 kg	n.a.	n.a.	0.2 kg	n.a.	n.a.	n.a.	n.a.	n.a.
2 t	0.4 kg	0.2 kg	n.a.	0.4 kg	0.2 kg	n.a.	0.2 kg	0.2 kg	n.a.
3 t	0.6 kg	0.22 kg	0.22 kg	0.6 kg	0.22 kg	0.22 kg	0.2 kg	0.2 kg	0.2 kg
5 t	1 kg	0.36 kg	0.36 kg	1 kg	0.36 kg	0.36 kg	0.34 kg	0.2 kg	0.2 kg
10 t	2 kg	0.72 kg	0.72 kg	2 kg	0.72 kg	0.72 kg	0.67 kg	0.24 kg	0.24 kg
20 t	4 kg	1.43 kg	1 kg	4 kg	1.43 kg	1 kg	1.34 kg	0.48 kg	0.34 kg
30 t	6 kg	2.15 kg	1.5 kg	6 kg	2.15 kg	1.5 kg	2 kg	0.72 kg	0.5 kg
50 t	10 kg	3.58 kg	2.5 kg	10 kg	3.58 kg	2.5 kg	3.34 kg	1.2 kg	0.84 kg
60 t	12 kg	4.29 kg	3 kg	12 kg	4.29 kg	3 kg	4 kg	1.43 kg	1 kg
75 t	15 kg	5.36 kg	3.75 kg	15 kg	5.36 kg	3.75 kg	5 kg	1.79 kg	1.25 kg



## Easy replacement:

All the accessories and mounting kits for the load cell PR 6201 are still compatible with the Inteco®!

Mounting kit PR 6001														
Maximum capacity of load cell Inteco®	Mounting kit/ accessories	Material	Description/ comments	Mounting screws (not included in delivery)	Installation height (mm)	Max. permissible horizontal force (kN)	Horizontal destructive force [kN]	Lifting destructive force [kN]	Max. permissible lift-off force (kN)	Max. permissible eccentricity	Max. permissible vertical load without load cell	Max. permissible load for jack-up	CE approval according to EN 1090	
500 kg – 10 t	PR 6001/00N	Steel electrogalvanised, chromated and sealed (RoHS compliant)	Mounting disc incl. upper load disc	M12-8.8	190.5	/	20	50	20	±5	25 t	1.5 t	Yes	
	PR 6001/00S	Stainless steel 1.4301 (AISI 304)	Mounting kit incl. upper and lower load disc	M12-A2-70			20	50					/	
	PR 6001/10N	Steel electrogalvanised, chromated and sealed (RoHS compliant)	MaxiFLEXLOCK	M12-8.8		25	45	50					Yes	
	PR 6001/10S	Stainless steel 1.4301 (AISI 304)	MaxiFLEXLOCK	M12-A2-70			39	50					/	
	PR 6001/20N	Steel electrogalvanised, chromated and sealed (RoHS compliant)	MaxiFLEXLOCK	M16-8.8		50	100	50					Yes	
	PR 6001/20S	Stainless steel 1.4301 (AISI 304)	MaxiFLEXLOCK	M16-A2-70			100	50					/	
	PR 6001/30N	Steel electrogalvanised, chromated and sealed (RoHS compliant)	High-load mounting kit incl. upper load disc	M20-8.8	250.5	200	236	250	180	±5	25 t	1.5 t	Yes	
20 t – 75 t	PR 6001/01N	Steel electrogalvanised, chromated and sealed (RoHS compliant)	Mounting kit including upper load disc	M12-8.8	190.5	/	20	50	30	±5	25 t	/	Yes	
	PR 6001/01S	Stainless steel 1.4301 (AISI 304)	Mounting kit incl. upper and lower load disc	M12-A2-70			20	50					/	
	PR 6001/11N	Steel electrogalvanised, chromated and sealed (RoHS compliant)	MaxiFLEXLOCK	M12-8.8		25	45	50					Yes	
	PR 6001/11S	Stainless steel 1.4301 (AISI 304)	MaxiFLEXLOCK	M12-A2-70			39	50					/	
	PR 6001/21N	Steel electrogalvanised, chromated and sealed (RoHS compliant)	MaxiFLEXLOCK	M16-8.8		50	100	50					Yes	
	PR 6001/21S	Stainless steel 1.4301 (AISI 304)	MaxiFLEXLOCK	M16-A2-70			100	50					/	
	PR 6001/26N	Steel electrogalvanised, chromated and sealed (RoHS compliant)	MaxiFLEXLOCK	M20-8.8	250.5	50	100	250	180	±5	25 t	/	Yes	
	PR 6001/31N	Steel electrogalvanised, chromated and sealed (RoHS compliant)	High-load mounting kit incl. upper load disc	M20-8.8		200	236	250					Yes	

## Mounting kit PR 6143

Maximum capacity of load cell Inteco®	Mounting kit/ accessories	Material	Description/ comments	Mounting screws (not included in delivery)	Horizontal destructive force [kN]	Installation height (mm)	Max. permissible horizontal force (kN)	Max. permissible lift-off force (kN)**	CE approval according to EN 1090
500 kg – 10 t	PR 6143/24S	Stainless steel 1.4542	Lower load disc	/	70	/	/	/	/
20 t – 75 t	PR 6143/54S	Stainless steel 1.4542	Lower load disc	/	/	/	/	/	/
500 kg – 75 t	PR 6143/50N	Steel electrogalvanised, chromated and sealed (RoHS compliant)	Upper load disc	/	/	/	/	/	/
	PR 6143/50S	Stainless steel 1.4542	Upper load disc	/	/	/	/	/	/
	PR 6143/00N	Steel electrogalvanised, chromated and sealed (RoHS compliant)	MiniFLEXLOCK incl. upper load disc	M12-8.8	35	190.5	25	50	Yes
	PR 6143/00S	Stainless steel 1.4301 (AISI 304)	MiniFLEXLOCK incl. upper and lower load disc*	M12-A2-70	35				/
	PR 6143/10N	Steel electrogalvanised, chromated and sealed (RoHS compliant)	MiniFLEXLOCK incl. upper load disc	M16-8.8	70		50	60	Yes
PR 6143/10S	Stainless steel 1.4301 (AISI 304)	MiniFLEXLOCK incl. upper and lower load disc*	M16-A2-70	70	/				

\* Lower load disc only for 0.5 t–10 t,  
for 20 t–75 t please order lower load disc PR 6143/54S separately

\*\* With separate threaded bolt of strength class 8.8 or A2-70

## Mounting kit PR 6144

Maximum capacity of load cell Inteco®	Mounting kit/ accessories	Material	Description/ comments	Mounting screws (not included in delivery)	Installation height (mm)	CE approval according to EN 1090	Horizontal destructive force [kN]	Lifting destructive force [kN]	Max. permissible lift-off force (kN)	Max. permissible vertical load without load cell	CE approval according to EN 1090
500 kg – 75 t	PR 6144/54N	Steel electrogalvanised, chromated and sealed (RoHS compliant)	Seismic Mount incl. load cell dummy	M30-8.8	217	370	600	600	400	16 t	Yes

## Mounting kit PR 6145

Maximum capacity of load cell Inteco®	Mounting kit/ accessories	Material	Description/ comments	Mounting screws (not included in delivery)	Installation height (mm)	CE approval according to EN 1090
500 kg – 75 t	PR 6145/00N	Steel electrogalvanised, chromated and sealed (RoHS compliant)	Plate mounting kit incl. upper load disc	M12-8.8	190.5	Yes
	PR 6145/00S	Stainless steel 1.4301 (AISI 304)	Plate mounting kit incl. upper and lower load disc*	M12-A2-70		/

\* Lower load disc only for 0.5 t–10 t,  
for 20 t–75 t please order lower load disc PR 6143/54S separately

## Fixed bearing PR 6101

Maximum capacity of load cell Inteco®	Fixed bearing	Material	Mounting screws (not included in delivery)	Installation height (mm)	Max. usable load	Horizontal destructive force [kN]	Permissible horizontal force for usable load (kN)
5 t	PR 6101/53N	Steel electrogalvanised, chromated and sealed (RoHS compliant)	M12-8.8	190.5	5 t	25	15
					10 t		12
	PR 6101/53S	Stainless steel 1.4301 (AISI 304)	M12-A2-70		5 t	16	10
					10 t		8.5
20 t	PR 6101/24N	Steel electrogalvanised, chromated and sealed (RoHS compliant)	M12-8.8	190.5	20 t	80	45
					40 t		35
	PR 6101/24S	Stainless steel 1.4301 (AISI 304)	M12-A2-70		20 t	40	30
					40 t		20
75 t	PR 6101/54N	Steel electrogalvanised, chromated and sealed (RoHS compliant)	M12-8.8	190.5	50 t	250	100
					75 t		80
	PR 6101/54S	Stainless steel 1.4301 (AISI 304)	M12-A2-70		50 t	150	50
					75 t		20

## Converter Connexx®



Fitted with the converter Connexx®, the load cell Inteco® offers a whole host of possibilities:

- The digital version guarantees fast signalling times for reliable dosing processes.
- Thanks to the use of field bus communication, the cable junction box is no longer needed.
- The standard interface CANopen ensures straightforward installation and calibration.
- CANopen allows for extra-long communication paths of up to 200 m.
- Weight values can also be generated individually – per load cell – meaning that defective load cells can be identified more easily.

# Technical diagrams

## Load cells Inteco®/PR 6203

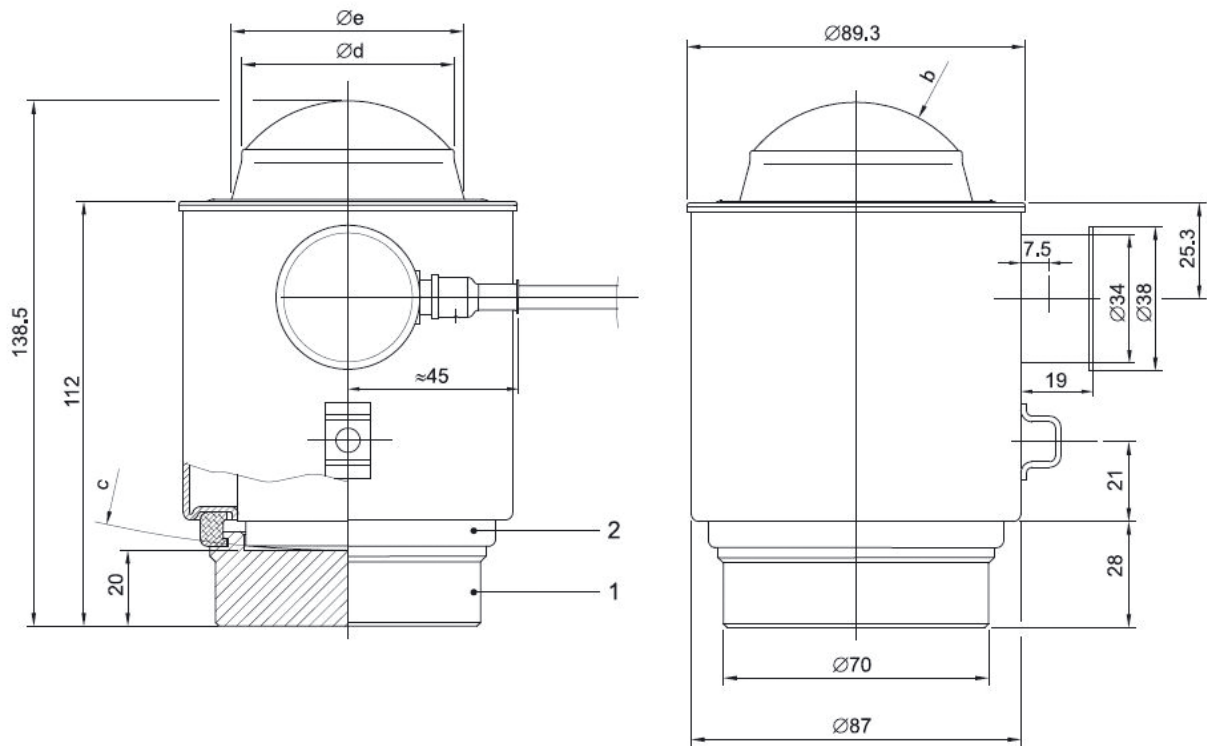

Pos.	Designation
1	Lower load disc
2	Support ring

Model	b Spherical radius	c Spherical radius	d	e
Inteco®/500 kg...3 t	15	150	24	32
Inteco®/5 t...10 t	15	150	34	44
Inteco®/20 t...75 t	35	220	56	62

Load cell Inteco®

## Converter Connex®

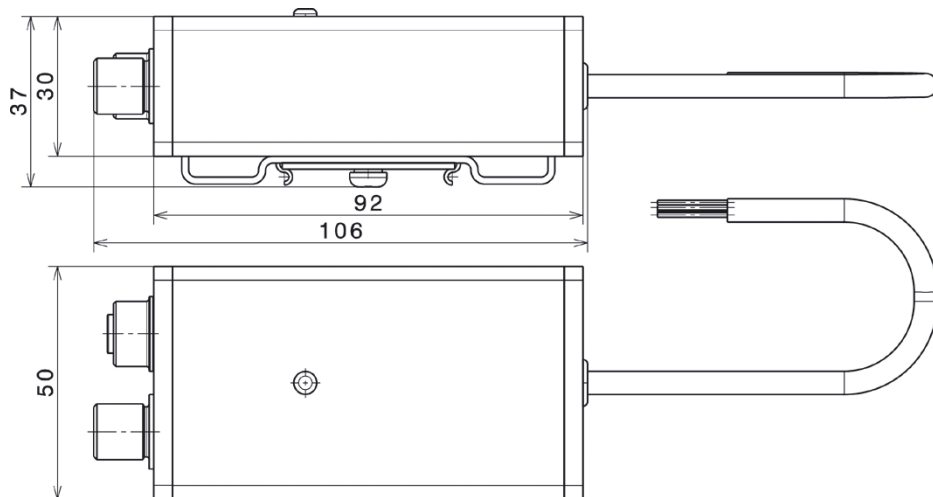

Converter Connex®

## Mounting kit PR 6001

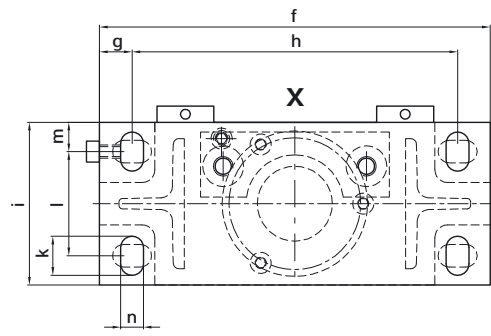
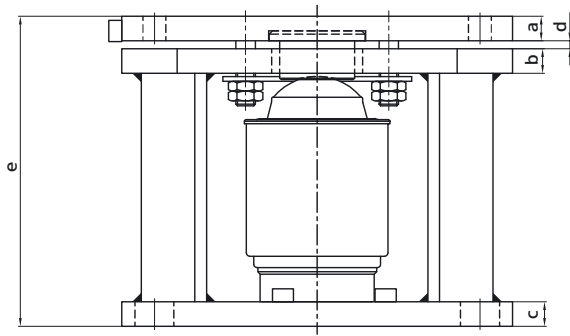

Mounting kit	a	b	c	d	e	f	g	h	i	k	l	m	n
PR 6001/00	15	15	15	5	190.5	240	20	200	100	24	64	18	14
PR 6001/01	15	15	15	5	190.5	240	20	200	100	24	64	18	14

Mounting kits PR 6001/00N+S, PR 6001/01N+S

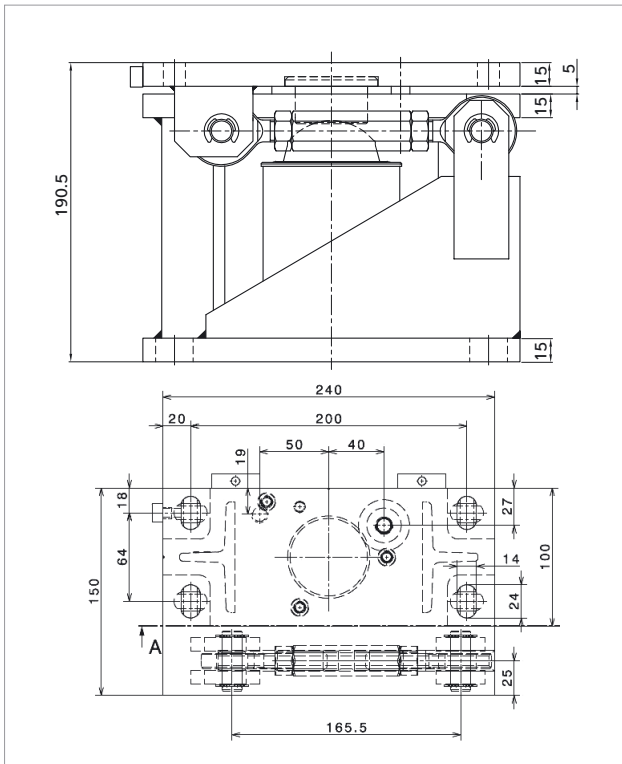

Mounting kit PR 6001/10N+S

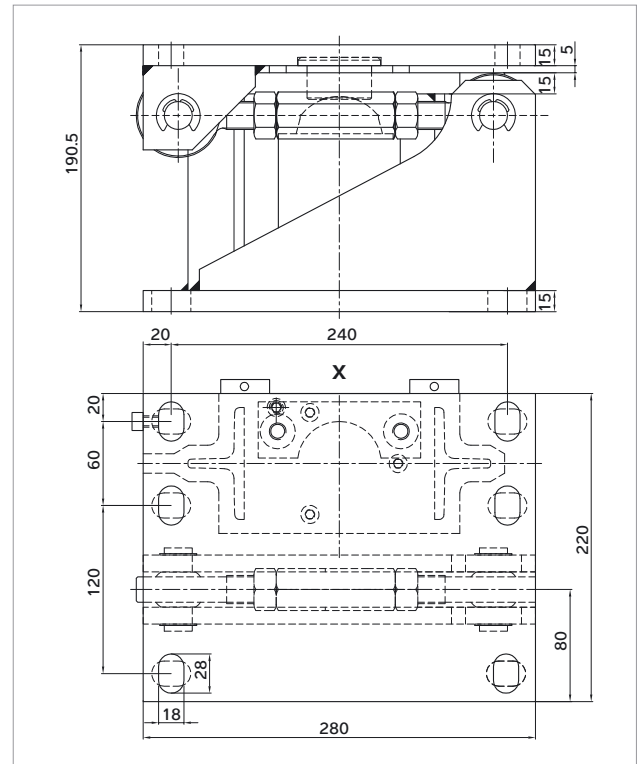

Mounting kit PR 6001/20N+S



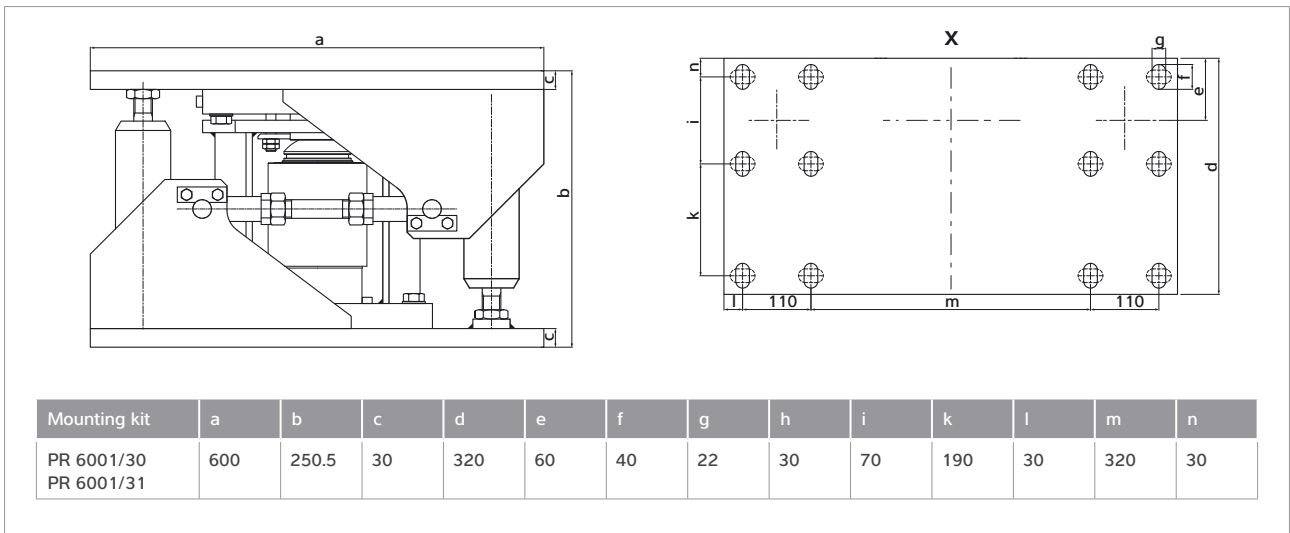

Mounting kits PR 6001/30N, PR 6001/31N

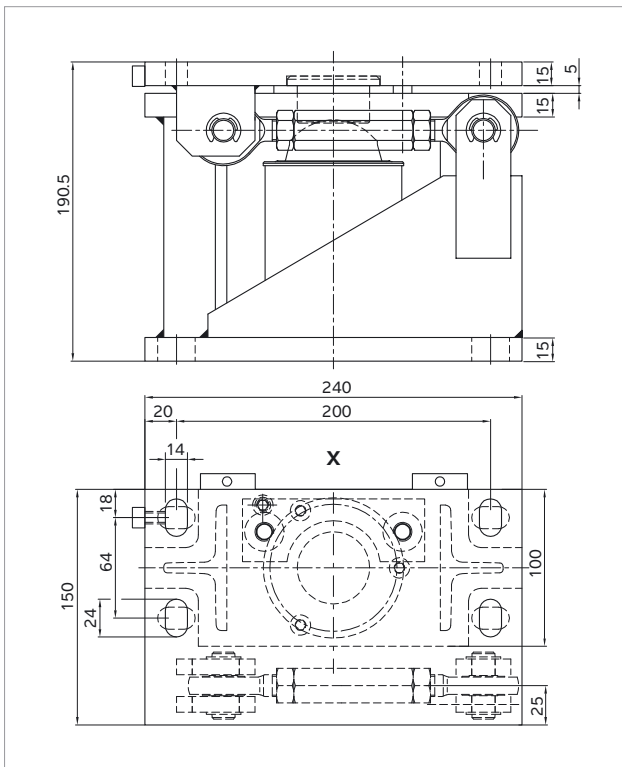

Mounting kit PR 6001/11N+S

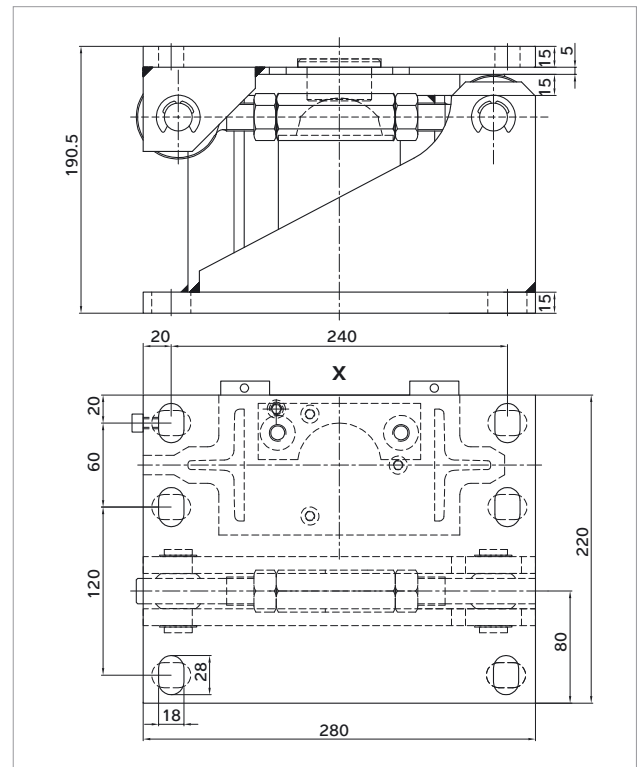

Mounting kit PR 6001/21N+S

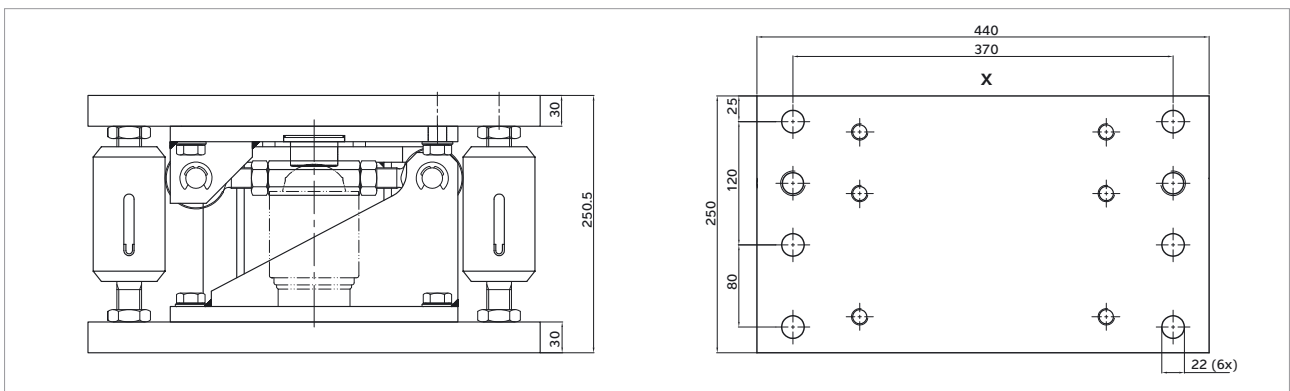

Mounting kit PR 6001/26N

## Mounting kit PR 6143

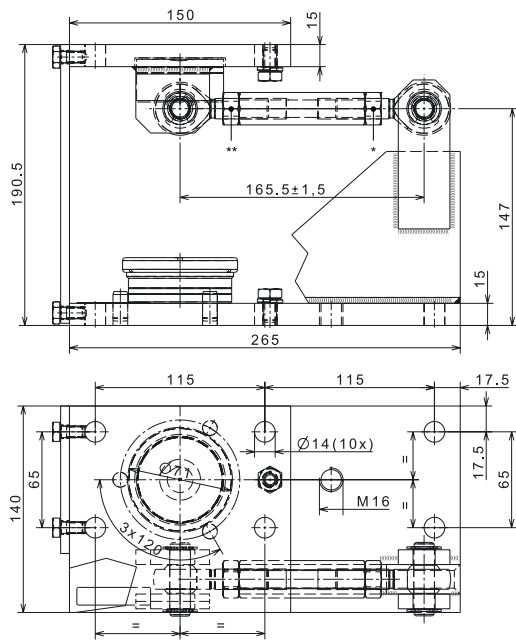

Mounting kit PR 6143/00N+S

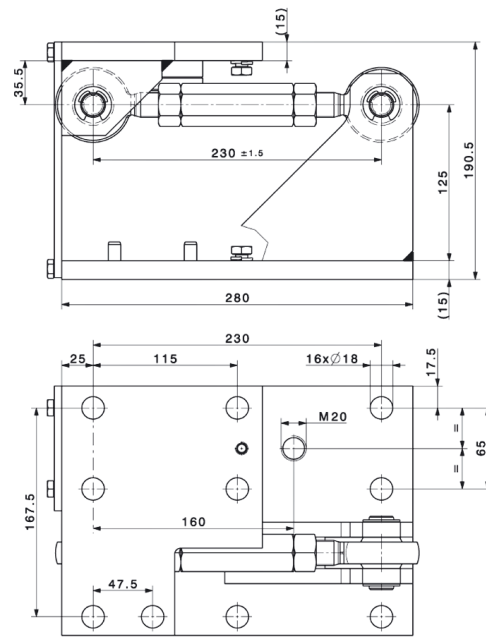

Mounting kit PR 6143/10N+S

## Mounting kit PR 6144

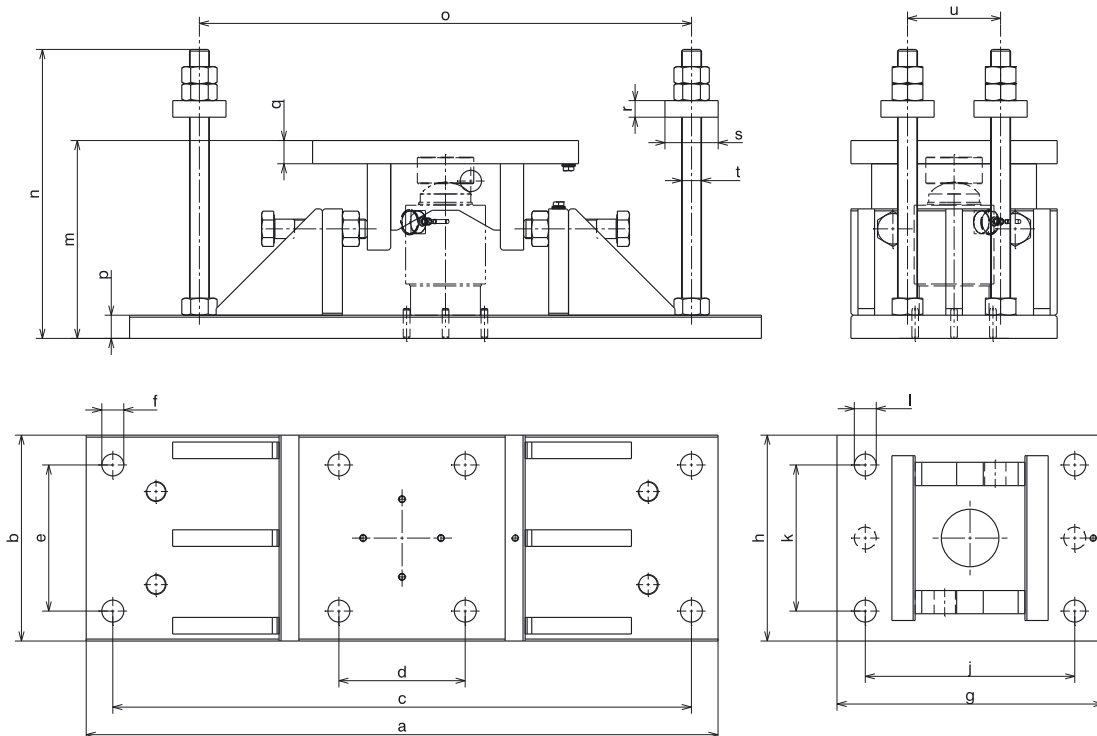

Model	a	b	c	d	e	f	g	h	j	k	l	m	n	o	p	q	r	s	t	u
PR 6144/54	820	240	740	160	160	Ø33	380	240	300	160	Ø33	217	350	620	30	30	25	Ø80	M30	120

Mounting kit PR 6144/54N

## Mounting kit PR 6145/xx

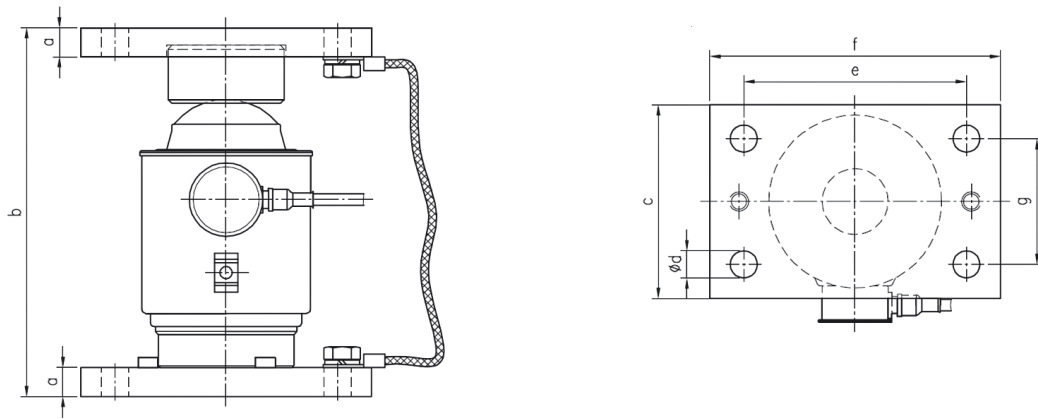

Model	a	b	c	d	e	f	g
PR 6145/00	15	190.5	100	14	115	150	65

Mounting kit PR 6145/00

## Fixed bearing PR 6101/xx

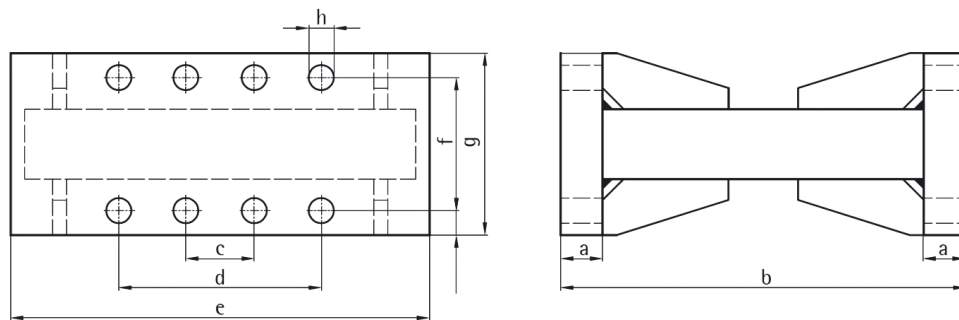

Model	a	b	c	d	e	f	g	h
PR 6101/53	15	190.5	-	115	150	65	100	14 (4×)
PR 6101/24	15	190.5	-	115	150	65	100	14 (4×)
PR 6101/54	15	190.5	115	199	250	65	100	14 (8×)

Fixed bearing PR 6101/53, PR 6101/24, PR 6101/54

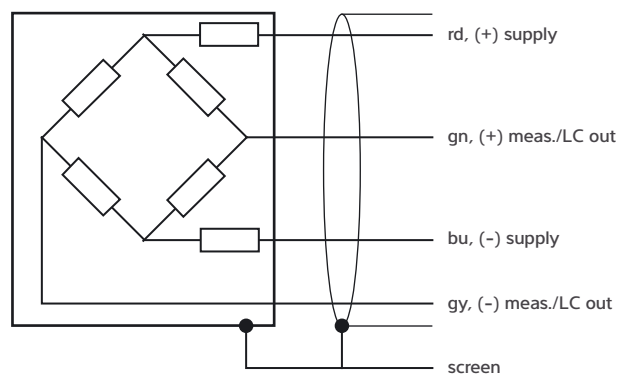

Connection diagram

# Ex approval

## Scope of validity:

Inteco® (0.5 t – 75 t)



Explosion protection

### Certificates precision compression load cell Inteco®/PR 6203

Zone	Labelling	Certificate number	For
0 and 1	II 1G Ex ia IIC T6 Ga Ex ia IIC T6 Ga	BVS 17 ATEX E 111X IECEX BVS 17.0092X	Inteco®/..E only
20 and 21	II 1D Ex ta IIIC T160°C Da Ex ta IIIC T160°C Da	TÜV 03 ATEX 2301X IECEX TUN 17.0025X	All Inteco® without /..E
2	II 3G Ex nA IIC T6 Gc	Manufacturer's declaration	All Inteco® without /..E
22	II 3D Ex tc IIIC T85°C Dc	Manufacturer's declaration	All Inteco® without /..E
FMus	IS CL I, II, II, DIV 1, GP A, B, C, D, E, F, G Entity - 4012 101 5688 NI CL I, II, II, DIV 2, GP A, B, C, D, E, F, G NIFW - 4012 101 5688 T4A Ta= -30°C to 70°C; T5 Ta= -30°C to 55°C	FM17US0276	All Inteco® without /..E
FMca	IS CL I, II, II, DIV 1, GP A, B, C, D, E, F, G Entity - 4012 101 5688 NI CL I, II, II, DIV 2, GP A, B, C, D, E, F, G NIFW - 4012 101 5688 T4A Ta= -40°C to 70°C; T5 Ta= -40°C to 55°C	FM17CA0138	All Inteco® without /..E



## Ordering information



Compression load cell Inteco®/PR 6203, OIML R60 accuracy class D1 = 0.05%			
Type	Load stage	Order number	Converter Connexx® as an option*
Inteco®/PR 6203 – 500 kg D1	500 kg	940520301150	•
Inteco®/PR 6203 – 1 t D1	1 t	940520301210	•
Inteco®/PR 6203 – 2 t D1	2 t	940520301220	•
Inteco®/PR 6203 – 3 t D1	3 t	940520301230	•
Inteco®/PR 6203 – 5 t D1	5 t	940520301250	•
Inteco®/PR 6203 – 10 t D1	10 t	940520301310	•
Inteco®/PR 6203 – 20 t D1	20 t	940520301320	•
Inteco®/PR 6203 – 30 t D1	30 t	940520301330	•
Inteco®/PR 6203 – 50 t D1	50 t	940520301350	•
Inteco®/PR 6203 – 60 t D1	60 t	940520301360	•
Inteco®/PR 6203 – 75 t D1	75 t	940520301375	•

Compression load cell Inteco®/PR 6203, OIML R60 accuracy class D1 = 0.05%, Ex version			
Type	Load stage	Order number	Converter Connexx® as an option*
Inteco®/PR 6203 – 500 kg D1E	500 kg	940560301150	
Inteco®/PR 6203 – 1 t D1E	1 t	940560301210	
Inteco®/PR 6203 – 2 t D1E	2 t	940560301220	
Inteco®/PR 6203 – 3 t D1E	3 t	940560301230	
Inteco®/PR 6203 – 5 t D1E	5 t	940560301250	
Inteco®/PR 6203 – 10 t D1E	10 t	940560301310	
Inteco®/PR 6203 – 20 t D1E	20 t	940560301320	
Inteco®/PR 6203 – 30 t D1E	30 t	940560301330	
Inteco®/PR 6203 – 50 t D1E	50 t	940560301350	
Inteco®/PR 6203 – 60 t D1E	60 t	940560301360	
Inteco®/PR 6203 – 75 t D1E	75 t	940560301375	

Compression load cell Inteco®/PR 6203, OIML R60 accuracy class C3 = 0.015%			
Type	Load stage	Order number	Converter Connexx® as an option*
Inteco®/PR 6203 – 2 t C3	2 t	940520303220	•
Inteco®/PR 6203 – 3 t C3	3 t	940520303230	•
Inteco®/PR 6203 – 5 t C3	5 t	940520303250	•
Inteco®/PR 6203 – 10 t C3	10 t	940520303310	•
Inteco®/PR 6203 – 20 t C3	20 t	940520303320	•
Inteco®/PR 6203 – 30 t C3	30 t	940520303330	•
Inteco®/PR 6203 – 50 t C3	50 t	940520303350	•
Inteco®/PR 6203 – 60 t C3	60 t	940520303360	•
Inteco®/PR 6203 – 75 t C3	75 t	940520303375	•

\* In combination with the converter Connexx®, the load cell is also available as a digital version

### Compression load cell Inteco®/PR 6203, OIML R60 accuracy class C3=0.015%, Ex version

Type	Load stage	Order number	Converter Connexx® as an option*
Inteco®/PR 6203 – 2 t C3E	2 t	940560303220	
Inteco®/PR 6203 – 3 t C3E	3 t	940560303230	
Inteco®/PR 6203 – 5 t C3E	5 t	940560303250	
Inteco®/PR 6203 – 10 t C3E	10 t	940560303310	
Inteco®/PR 6203 – 20 t C3E	20 t	940560303320	
Inteco®/PR 6203 – 30 t C3E	30 t	940560303330	
Inteco®/PR 6203 – 50 t C3E	50 t	940560303350	
Inteco®/PR 6203 – 60 t C3E	60 t	940560303360	
Inteco®/PR 6203 – 75 t C3E	75 t	940560303375	

### Compression load cell Inteco®/PR 6203, OIML R60 accuracy class C6 = 0.008%

Type	Load stage	Order number	Converter Connexx® as an option*
Inteco®/PR 6203 – 3 t C6	3 t	940520306230	
Inteco®/PR 6203 – 5 t C6	5 t	940520306250	
Inteco®/PR 6203 – 10 t C6	10 t	940520306310	
Inteco®/PR 6203 – 20 t C6	20 t	940520306320	•
Inteco®/PR 6203 – 30 t C6	30 t	940520306330	•
Inteco®/PR 6203 – 50 t C6	50 t	940520306350	
Inteco®/PR 6203 – 60 t C6	60 t	940520306360	
Inteco®/PR 6203 – 75 t C6	75 t	940520306375	

### Compression load cell Inteco®/PR 6203, OIML R60 accuracy class C6 = 0.008%, Ex version

Type	Load stage	Order number	Converter Connexx® as an option*
Inteco®/PR 6203 – 3 t C6E	3 t	940560306230	
Inteco®/PR 6203 – 5 t C6E	5 t	940560306250	
Inteco®/PR 6203 – 10 t C6E	10 t	940560306310	
Inteco®/PR 6203 – 20 t C6E	20 t	940560306320	
Inteco®/PR 6203 – 30 t C6E	30 t	940560306330	
Inteco®/PR 6203 – 50 t C6E	50 t	940560306350	
Inteco®/PR 6203 – 60 t C6E	60 t	940560306360	
Inteco®/PR 6203 – 75 t C6E	75 t	940560306375	

### Compression load cell Inteco®/PR 6203, Converter Connexx®

Type	Description	Order number
Converter Connexx®	The converter Connexx® can only be ordered with the above-mentioned load cells from the Inteco® series. When ordering, both order numbers need to be given.	940510300000

### Compression load cell Inteco®/PR 6203, Converter Connexx® – Application sets

Type	Description	Order number
PR 6154/03	Application set for 3 load cells. Including: 2 × PR 6155/05, 1 × PR 6152/25, 1 × PR 6153/99	94053615403
PR 6154/04	Application set for 4 load cells. Including: 3 × PR 6155/05, 1 × PR 6152/25, 1 × PR 6153/99	940536154041

\* In combination with the converter Connexx®, the load cell is also available as a digital version

## Compression load cell Inteco®/PR 6203, Converter Connexx® – Accessories

Type	Description	Order number
PR 6152/10	Connection cable between Connexx® and X3 (10 m)	940536152101
PR 6152/25	Connection cable between Connexx® and X3 (25 m)	940536152251
PR 6152/40	Connection cable between Connexx® and X3 (40 m)	940536152401
PR 6153/98	Split cable gland	940536153981
PR 6153/99	Terminal resistor for Connexx®, M12	940536153991
PR 6155/05	Connection cable between Connexx® and Connexx® (5 m)	940536155051
PR 6155/10	Connection cable between Connexx® and Connexx® (10 m)	940536155101

### Additional information:

The converters Connexx® can be used with the Indicator X3.

To do this, the indicator X3 must be equipped with a CANopen interface card PR 5510/05 (940535510051).

### Mounting kit PR 6145 without constrainer

Type	Order number
PR 6145/00N	940536145001
PR 6145/00S	940536145002

### MiniFLEXLOCK with integrated constrainer

Type	Order number
PR 6143/00N	940536143001
PR 6143/00S	940536143002
PR 6143/10N	940536143101
PR 6143/10S	940536143102

### Constrainer for compression load cell Inteco®/PR 6203

Type	Order number
PR 6143/80	940536143801
PR 6143/83	940536143831
PR 6152/02	940536152021

### Upper load discs for compression load cell Inteco®/PR 6203

Type	Order number
PR 6143/50N	940536143501
PR 6143/50S	940536143502

### Lower load discs for compression load cell Inteco®/PR 6203

Type	Order number
PR 6143/24S	940536143242
PR 6143/54S	940536443542

### Fixed bearing

Type	Order number
PR 6101/53N	940556101531
PR 6101/53S	940556101532
PR 6101/24N	940556101241
PR 6101/24S	940556101242
PR 6101/54N	940556101541
PR 6101/54S	940556101542

### Compact mounting kits

Type	Order number
PR 6001/00N	940536001001
PR 6001/00S	940536001002
PR 6001/01N	940536001011
PR 6001/01S	940536001012

### MaxiFLEXLOCK with integrated constrainer

Type	Order number
PR 6001/10N	940536001101
PR 6001/10S	940536001102
PR 6001/11N	940536001111
PR 6001/11S	940536001112
PR 6001/20N	940536001201
PR 6001/20S	940536001202
PR 6001/21N	940536001211
PR 6001/21S	940536001212
PR 6001/26N	940536001261

### High-load MaxiFLEXLOCK with a permissible horizontal force of 200 kN

Type	Order number
PR 6001/30N	940536001301
PR 6001/31N	940536001311

### Seismic Mount for compression load cell Inteco®/PR 6203

Type	Order number
PR 6144/54N	940536144541
PR 6144/15N	940536144151
PR 6144/35N	940536144351
PR 6144/55N	940536144551

### Weld-on plate kits

Type	Order number
PR 6001/90N	940536001901
PR 6001/90S	940536001902
PR 6001/91N	940536001911
PR 6001/91S	940536001912
PR 6001/92N	940536001921
PR 6001/92S	940536001922
PR 6001/96N	940536001961
PR 6001/98N	940536001981

The products and solutions presented in this data sheet make major contributions in the following sectors:



Food and beverages



Chemistry



Agribusiness



Building materials



Machinery (OEM)

The technical data given serves as a product description only and should not be understood as guaranteed properties in the legal sense.

Specifications subject to change without notice.  
Rev. 03/2020

Minebea Intec GmbH  
Meiendorfer Straße 205 A  
22145 Hamburg, Germany  
Phone +49.40.67960.303  
sales.hh@minebea-intec.com  
www.minebea-intec.com